



10 N. Fifth St., Suite 800, Reading, PA 19601 **610-375-9301** Fax 610-375-9302 www.libertyenviro.com

July 24, 2008

Ms. Barbara Bloomfield  
Pennsylvania Department of Environmental Protection  
2 East Main Street  
Norristown, PA 19401

**Re: Remedial Action Plan Addendum  
Operation of Remediation System in Stream Discharge Mode  
Len's Hartsville Garage  
Warwick Township, Bucks County, PA  
DEP Facility ID #09-27935  
Liberty Project No. 060006**

Dear Ms. Bloomfield:

Liberty Environmental, Inc. (Liberty) is pleased to provide you with this Remedial Action Plan Addendum (RAP) for the above-referenced site. As you know, due to manganese levels exceeding Warminster Municipal Authority (WMA) discharge limits in the system effluent and a premature breakthrough of MTBE in the activated carbon vessels, we have temporarily ceased discharging to the municipal sewer and are operating the system in pump-and-haul mode. In order to reduce remediation costs and provide for an alternative to sewer discharge if future issues arrive with the Warminster Municipal Authority, Liberty has submitted to DEP an application for coverage under NPDES General Permit PAG-05. When issued, this permit will allow us to haul treated effluent to an approved discharge point along the Little Neshaminy Creek. Modifications to the remediation system are necessary to enable this option to be utilized.

The proposed modifications to the system will include installation of a small oil/water separator to prevent any recovered free product from fouling the activated carbon vessels, and use of the 3,000-gallon oil/water separator as a holding tank for treated groundwater. A diagram of the small oil/water separator that is being installed (AFL Industries model VTC-20A) is attached. The oil/water separator has a flow capacity of 20 gallons per minute (gpm), which is much greater than the average groundwater recovery rate of 1 gpm. After passing through the oil/water separator, recovered groundwater will flow through bag filters for sediment removal, then through three in-series 55-gallon activated carbon vessels for organics removal, and will then be contained in the 3,000-gallon tank. The tank is already equipped with a high-level shutoff device, and an additional device will also be added to the new oil/water separator. These are the only system components that are open to the atmosphere and could overflow in the event of a system blockage.

A process flow diagram and treatment system layout drawing depicting the new system configuration for operation in pump-and-stream discharge mode are included as Figures 1 and 2. A

process flow diagram and treatment system layout drawing depicting the new system configuration for operation in pump-and-sewer discharge mode are included as Figures 3 and 4. This configuration will include the ion exchange system for manganese removal that was described in our previous RAP Addendum dated June 16, 2008. One minor change from the ion exchange system described in that RAP Addendum is that instead of using two 55-gallon vessels, we will now be using six smaller vessels that each contains 1.9 cubic feet of ion exchange resin. This change was made to provide a smaller cross-sectional area through the vessel which will reduce the likelihood of channeling occurring in the media.

We look forward to receiving your approval of the system modifications proposed herein. If you have any questions or comments concerning the information presented herein, please feel free to contact us at 610-375-9301.

Sincerely,  
**Liberty Environmental, Inc.**

A handwritten signature in black ink, appearing to read "James P. Cinelli".

James P. Cinelli, P.E., BCEE  
Principal Consultant

cc: L. Rickert, Len's Hartsville Garage  
J. Builder, ICF Consulting  
G. Weniger, Warwick Township

Attachments:

- Figure 1: Process Flow Diagram in Stream Discharge Mode
- Figure 2: Treatment System Layout in Stream Discharge Mode
- Figure 3: Process Flow Diagram in Sewer Discharge Mode
- Figure 4: Treatment System Layout in Sewer Discharge Mode
- Attachment A: Oil/Water Separator Specification Sheet

**FIGURE 1**  
**PROCESS FLOW DIAGRAM – STREAM DISCHARGE MODE**

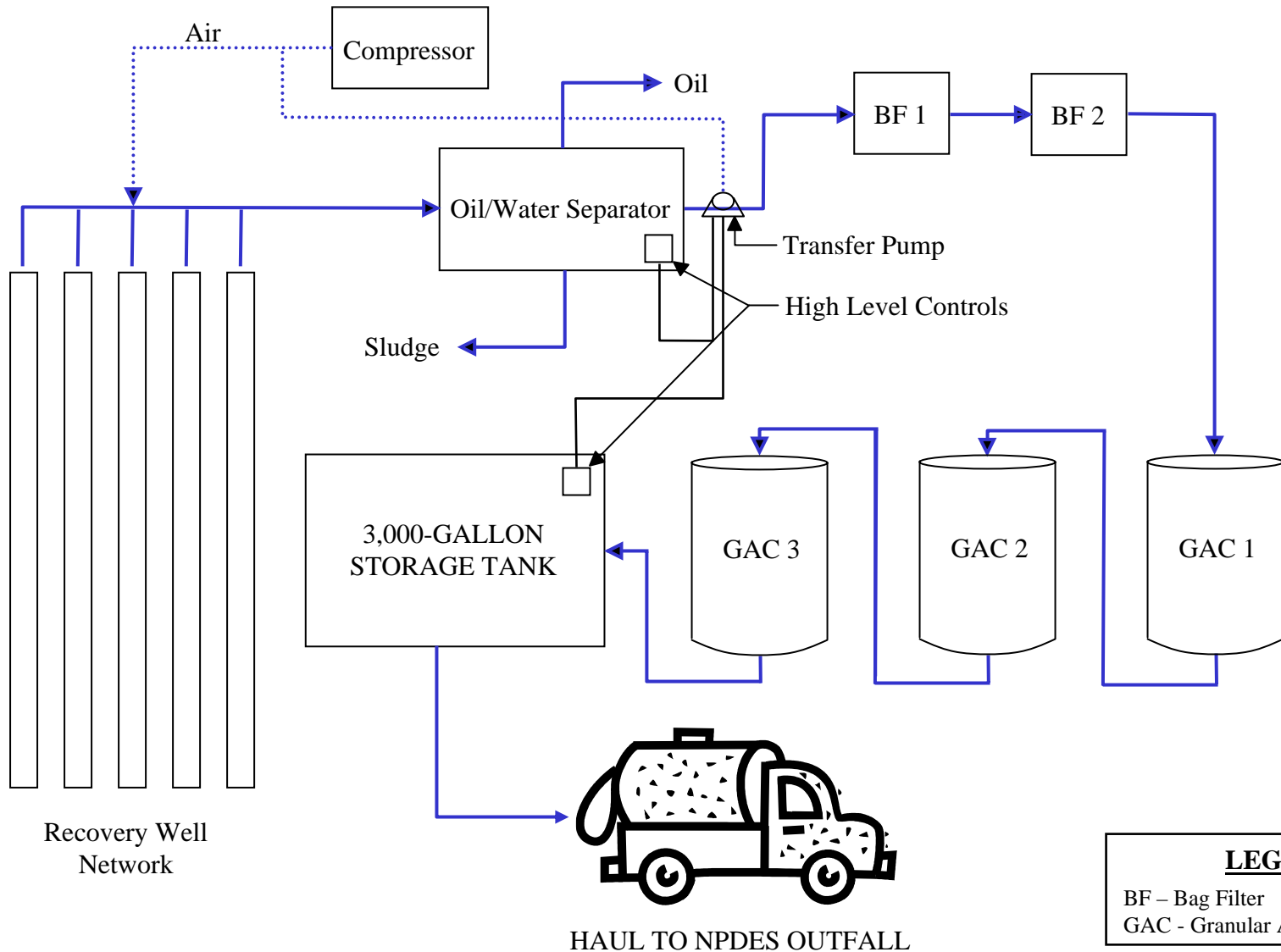

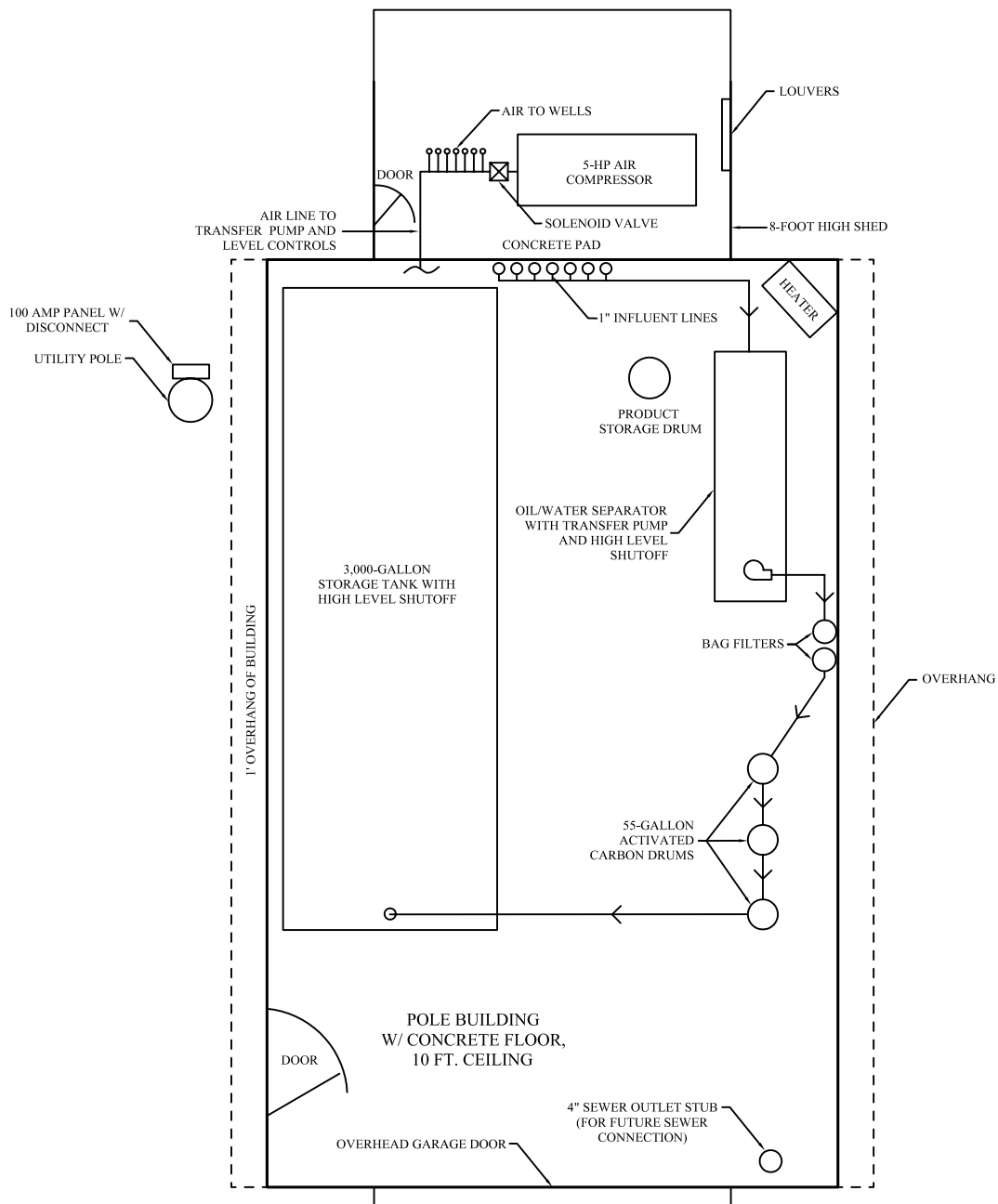

**Figure 2: Treatment System Layout in Stream Discharge Mode  
 Len's Hartsville Garage  
 1075 West Bristol Road  
 Warwick Township, Bucks County, PA**



10 N. Fifth St. Suite 800 Reading, PA 19601  
 Phone: 610-375-9301 Fax: 610-375-9302  
 www.libertyenviro.com

PROJECT NO. 060006	DRAWING NO.	REV
SCALE: 1" = 5'	PREPARED BY: JPB	APPROVED BY: JPC

**FIGURE 3**  
**PROCESS FLOW DIAGRAM – SEWER DISCHARGE MODE**

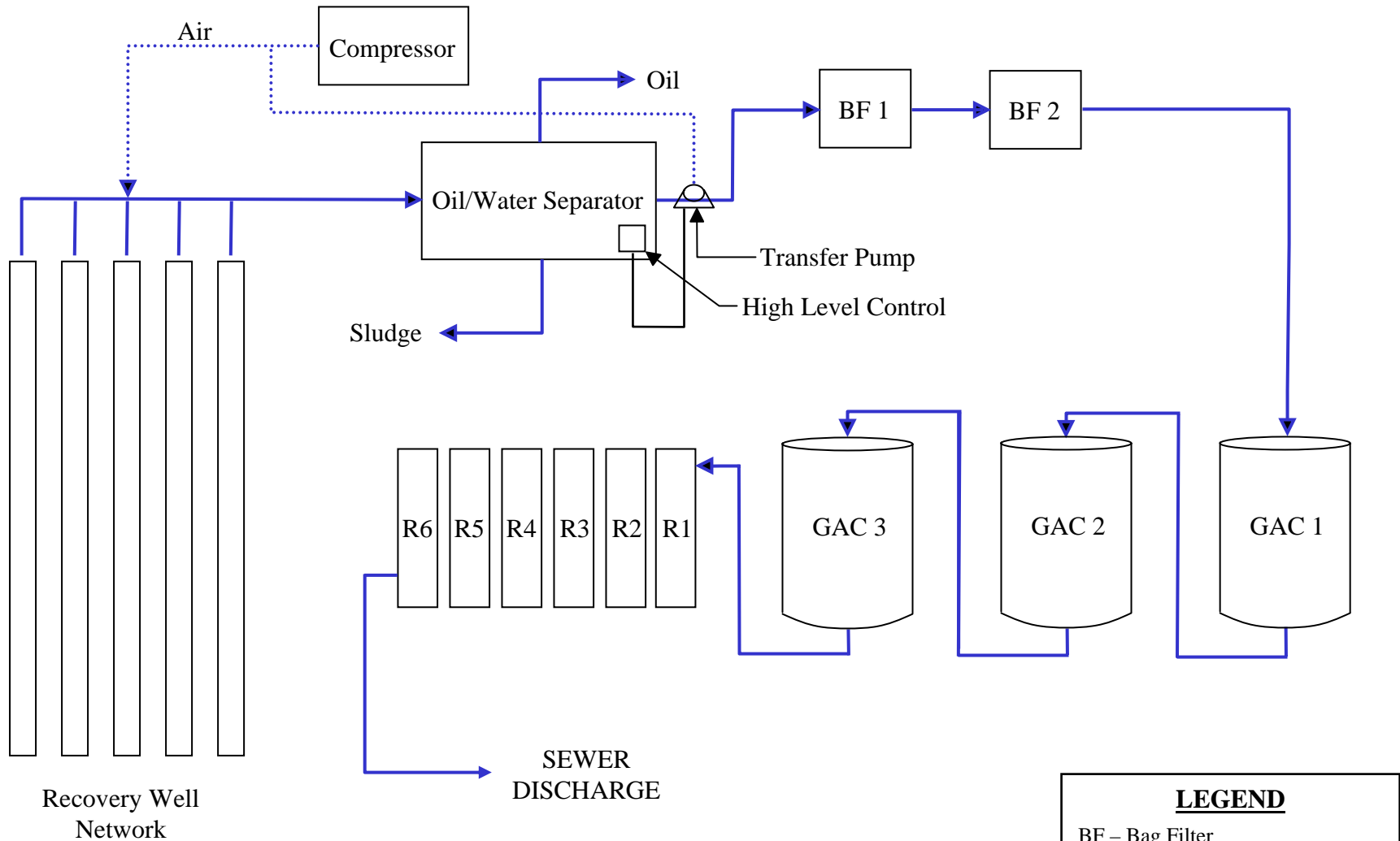

**LEGEND**  
BF – Bag Filter  
GAC - Granular Activated Carbon  
R – Ion Exchange Resin

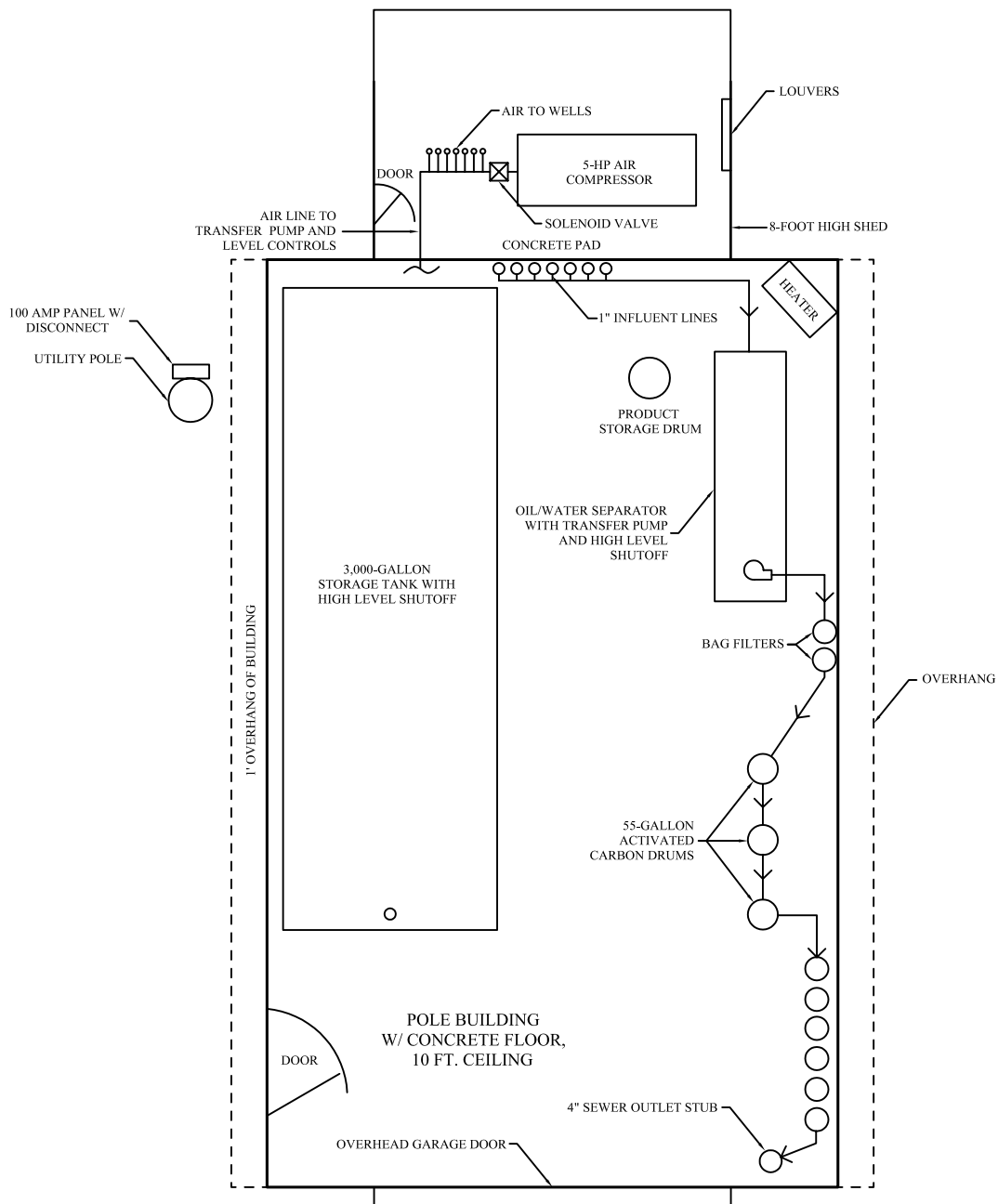

**Figure 4: Treatment System Layout in Sewer Discharge Mode  
 Len's Hartsville Garage  
 1075 West Bristol Road  
 Warwick Township, Bucks County, PA**



10 N. Fifth St. Suite 800 Reading, PA 19601  
 Phone: 610-375-9301 Fax: 610-375-9302  
 www.libertyenviro.com

PROJECT NO. 060006	DRAWING NO.	REV
SCALE: 1" = 5'	PREPARED BY: JPB	APPROVED BY: JPC

